

Hemet Unified School District Business Services

Annual Report of the Measure T Citizens' Oversight Committee



Presented to the Governing Board
March 5, 2013



2011-12 Measure T Annual Report Table of Contents

1.	INTRODUCTION	1
2.	AUTHORIZATION	1
3.	STATEMENT OF COMPLIANCE	1
4.	COMMITTEE MEMBERSHIP	2
5.	DUTIES OF THE COMMITTEE	2
5.1	Expenditure Review	2
5.2	Annual Report	3
6.	MEETINGS	3
7.	ACTIVITIES OF THE COMMITTEE	3
7.1	Budget Review	3
7.2	Project Updates	3
7.3	Annual Report	4
8.	SALE OF BONDS	4
9.	AUDIT	5
10.	PROJECTS	5
10.1	Measure T Bond Project List.....	5
10.2	Measure T Photo Exhibit.....	7
11.	PROJECT UPDATE AND BUDGET SUMMARY	7
11.1	Measure T Projects –Summary	7
12.	CONCLUDING STATEMENT	9

Attachments

A. **PHOTO EXHIBIT**

Annual Report of the Measure T Independent Citizens' Oversight Committee Hemet Unified School District

Presented to the Board of Education on March 5, 2013

1. INTRODUCTION

The Hemet Unified School District Independent Citizens' Oversight Committee is responsible for overseeing the expenditures of Measure T bond proceeds and reporting to the public, on an annual basis, the progress of the bonds and their status. The \$149 Measure T Bond was passed by the electorate of the Hemet Unified School District on November 7, 2006.

2. AUTHORIZATION

In November, 2000, the voters of the State of California authorized an amendment to the California Constitution (Proposition 39) lowering the voter-approval threshold from two-thirds to fifty-five percent for school districts, as long as certain requirements or restrictions are contained in the general obligation ballot language. Among the stipulations: The ballot measure must contain a specific list of projects, the amount of the bond authorization is limited, and a citizens' oversight committee must be appointed to oversee the expenditure of funds.

3. STATEMENT OF COMPLIANCE

The Committee is required to advise the public on the District's compliance with accountability requirements set forth in Article XIII A, Section 1(b)(3) of the California Constitution. This is the section of the State Constitution authorizing general obligation

bonds for the construction, reconstruction, rehabilitation, or replacement of school facilities, including the furnishing and equipping of school facilities, or the acquisition or lease of real property for school facilities, by 55 percent of the voters of the District voting on the proposition.

Based on a review of budgetary reports and documents presented to the committee by District staff, the Committee concludes that District expenditures of Measure T bond funds are in compliance with the provisions set forth in Measure T, and in conformity with the requirements of Article XIII A, Section 1(b)(3) of the California Constitution as noted above. Information in support of this conclusion is contained in this report.

4. COMMITTEE MEMBERSHIP

Representatives of the community serving on the committee are:

Arthur Almaguer	Bob Jungluth
Kathy Bloom-Rudibaugh, Chair	Wendy Naylor
Dale Brusewitz, Vice Chair	Robert Righetti
Steven Bunn	Ray Strait
Ronald Burke	Roger Wellman
James Calkins	

5. DUTIES OF THE COMMITTEE

To carry out its stated purpose, the following duties are set forth in the By-Laws of the Citizens' Oversight Committee:

5.1 Expenditure Review

Review expenditures to ensure that bond proceeds are expended only for purposes set forth in the ballot measure and ensure that no bond proceeds are used for teacher or administrative salaries or other operating expenses.

5.2 Annual Report

The Committee shall present to the Board of Education an Annual Written Report which shall include a statement indicating whether the District is in compliance with the requirements of Article XIII A, Section 1(b)(3) of the California Constitution; and a summary of the Committee's proceedings and activities for the preceding year.

6. **MEETINGS**

The COC meets quarterly at the District Office or at school sites. Project updates are provided at each meeting with photos/slides by District staff, along with special presentations from District consultants on topics of importance or interest. Agendas are developed from member request and staff input.

Agendas and minutes are posted on the Hemet Unified School District website and agendas are posted at the District Office and meeting locations. Meetings are held in accordance with the Ralph M. Brown Act (Open Meeting Laws).

7. **ACTIVITIES OF THE COMMITTEE**

7.1 Budget Review

The Committee receives financial reports for all Measure T expenditures, particularly Hemet High School, which include detailed expenditure reports showing encumbrances and uncommitted funds. Financial revenue and expenditure reports are presented in a format consistent with state reporting requirements. The Hemet High School project was partially funded by state funds, and is subject to a comprehensive audit by the Office of Public School Construction upon completion (in addition to annual District financial and performance audits as required by law).

7.2 Project Updates

The Committee is kept up to date on projects through reports from District staff, budget reports, and by meeting at project sites. The intent of Measure T is to provide funding to complete the renovation of Hemet High School and undertake other modernization projects throughout the District. Section 11 of this report

provides the budgets for each project and funds spent, as of December 31, 2012.

7.3 Annual Report

The Citizens' Oversight Committee is charged with preparing the Annual Report pursuant to Education Code Section 15280 and the COC by-laws. The COC appoints representatives each year to facilitate the development of the report for presentation to the Citizens' Oversight Committee as a whole for review and acceptance. The Annual Report is presented to the Board of Education by the COC Chair and members of the COC. After presentation to the Board of Education, the report in its entirety is placed on the HUSD website for public review.

8. **SALE OF BONDS**

The first series of Measure T Bonds (Series A) of \$60 million was issued March 1, 2007. Proceeds were spent only on construction, reconstruction, rehabilitation or replacement of school facilities including furnishings and equipping of school facilities on acquisition or lease of real property for school facilities as identified in the projects list of Resolution Number 1608 of the Hemet Unified School District.

The second series of Measure T (Series B) of \$40 million was issued in March, 2008. Proceeds were spent only on construction, reconstruction, rehabilitation or replacement of school facilities including furnishings and equipping of school facilities on acquisition or lease of real property for school facilities as identified in the projects list of Resolution Number 1608 of the Hemet Unified School District.

The district sold \$25 million in bond anticipation notes (BAN) in July 2010 which will be later refunded by Measure T general obligation bonds. The BAN will cover the cost to complete phase II and III of Hemet High School. The district used its eligibility in the federally backed Qualified School Construction Bond (QSCB) program to subsidize the interest cost of the BAN.

A new bond measure (Measure U) was passed in November, 2012 to reauthorize the remaining \$49 million of Measure T's authorization. Measure T will

decertify \$49 million making its total authorization \$100 million. Projects currently done with the QSCB (Bond Anticipation Notes) will be paid with Measure U bond proceeds when they are sold.

9. AUDIT

Pursuant to the requirements of Proposition 39, the Committee is charged with receiving and reviewing an annual financial and performance audit of the bond proceeds to ensure that funds have been spent solely on the specified list of projects. This requirement remains in effect until the entire amount of the bond proceeds has been spent.

The Independent Financial and Performance Audits were conducted by Vavrinek, Trine, Day & Co., LLP (VTD), and presented to the Citizens' Oversight Committee at its regular meeting on February 6, 2013. VTD presented the auditor's findings and opinion to the committee. The final audit report for the fiscal year ending June 30, 2012, is posted on the website and was approved at the January 8, 2013 Board Meeting. A copy was given to each Board Member at that time.

10. PROJECTS

The Hemet Unified School District School Construction and Improvement Bond of 2006 stated that the proceeds from the sale of bonds shall be used only for the construction, reconstruction, rehabilitation, or replacement of school facilities, including the furnishing and equipping of school facilities, as specified in the following Bond Project List, and not for any other purpose, including teacher and administrator salaries and other school operating expenses.

10.1 Measure T Bond Project List

CONSTRUCTION OF NEW SCHOOL FACILITIES

The Governing Board of the Hemet Unified School District has evaluated the School District's needs for new school facilities toward reducing overcrowding, maintaining and expanding class-size reduction and upgrades to existing school facilities for health and safety.

Project costs for the construction of new schools and school facilities, as listed below, may include, but not be limited to, site acquisition, construction services, architectural design, engineering, site improvements, inspection and testing services, plan review fees and interim financing, including the construction of classrooms, offices, cafeterias, multipurpose facilities, playing fields and other athletic facilities, school grounds, science,

technology and computer labs, library, restrooms, furniture and equipment and other school facilities. New school facilities projects are dependent on matching State funding availability.

Page Ranch Elementary School	Elementary School, Valle Vista area
Rancho Viejo Middle School	Hemet High School Expansion
Second Phase of Tahquitz High School	Additions to schools, various sites

UPGRADE AND MAJOR REPAIR OF EXISTING DISTRICT SCHOOL FACILITIES*

Project costs for upgrade and major repair of existing District school facilities may include, but is not limited to, the following: repair, renovation, reconstruction, upgrading and replacement of lighting and electrical systems; heating, air and ventilation systems, replacement of worn-out floors, roofs, windows, deteriorating wall systems; plumbing, pipes, fixtures and accessories; communication, bell and fire alarm systems, security systems, fencing, athletic facilities, site improvements; walkways, design costs, architect costs, plan preparation, and the addition of handicap accessibility improvements to ancillary facilities. Project

costs for furniture and equipment may include, but are not limited to some or all of the following: desks and tables; window and floor coverings (including tiles and carpeting); computer, media recording and presentation equipment, including, but not limited to, audio systems; kitchen equipment, improvements and furnishings; science laboratory equipment; and/or other electronic equipment.

<p>Acacia Middle School*</p> <ul style="list-style-type: none"> • Plumbing, electrical, mechanical systems and plant/classroom repairs. • Campus security, safety, technology, and accessibility projects. • Facility equity augmentation and equipment 	<p>Bautista Creek Elementary</p> <ul style="list-style-type: none"> • Campus security, safety, technology and accessibility projects. • Facility equity augmentation and equipment. • Replace portable classrooms.
<p>Cottonwood School</p> <ul style="list-style-type: none"> • Water well and fire protection, water conservation. • Plumbing, electrical, mechanical systems and plant/classroom repairs. • Campus security, safety, technology and accessibility projects • Facility equity augmentation and equipment. 	<p>Hamilton School (Elementary and Middle School)</p> <ul style="list-style-type: none"> • Permanent classroom additions • Replacement of portable classrooms. • Plumbing, electrical, mechanical systems and plant/classroom repairs. • Campus security, safety, technology, accessibility projects and water conversation. • Facility equity augmentation and equipment.
<p>Hemet Elementary School*</p> <ul style="list-style-type: none"> • Plumbing, electrical, mechanical systems and plant/classroom repairs. • Campus security, safety, technology and accessibility projects. • Facility equity augmentation and equipment 	<p>Hemet High School</p> <ul style="list-style-type: none"> • Plumbing, electrical, mechanical systems and plant/classroom repairs. • Campus security, safety, technology and accessibility projects. • Facility equity augmentation and equipment.
<p>Idyllwild School* (old campus)</p> <ul style="list-style-type: none"> • Plumbing, electrical, mechanical systems and plant/classroom repairs. • Campus security, safety, technology and accessibility projects. • Facility equity augmentation and equipment. 	<p>Little Lake Elementary School*</p> <ul style="list-style-type: none"> • Plumbing, electrical, mechanical systems and plant/classroom repairs. • Campus security, safety, technology and accessibility projects, • Classroom replacements and building additions. • Facility equity augmentation and equipment.
<p>Ramona Elementary School*</p> <ul style="list-style-type: none"> • Plumbing, electrical, mechanical systems and plant/classroom repairs. • Campus security, safety, technology and accessibility projects. • Classroom replacements and building additions. • Facility equity augmentation and equipment 	<p>Santa Fe Middle School*</p> <ul style="list-style-type: none"> • Plumbing, electrical, mechanical systems and plant/classroom repairs. • Campus security, safety, technology and accessibility projects. • Facility equity augmentation and equipment.
<p>Valle Vista Elementary School</p> <ul style="list-style-type: none"> • Campus security, safety, technology and accessibility 	<p>West Valley High School</p> <ul style="list-style-type: none"> • Campus security, safety, technology and accessibility

<i>projects.</i> • Facility equity augmentation and equipment.	<i>projects and site improvements.</i> • Facility equity augmentation and equipment.
Whittier Elementary School* • Plumbing, electrical, mechanical systems and plant/classroom repairs. • Campus security, safety, technology and accessibility projects. • Classroom replacements and building additions. • Facility equity augmentation and equipment.	Winchester Elementary School • Plumbing, electrical, mechanical systems and plant/classroom repairs. • Campus security, safety, technology and accessibility projects. • Classroom replacements and building additions. • Facility equity augmentation and equipment.

*Schools with facilities which are 30 years and older will be upgraded and repaired with proceeds from bonds and any eligible State matching funding.

10.2 Measure T Photo Exhibit

A photographic summary of Measure T funded projects is included as Exhibit A.

11. PROJECT UPDATE AND BUDGET SUMMARY

11.1 Measure T Projects – Summary as of 12/31/12

Site	Budget	Interest & Misc. Rev.	Spent	Encumbered	Uncommitted
Acacia Modernization Project	9,894,344	-	3,882,687	5,001,587	1,010,070
Bautista Creek Facility Equipment	1,410	5,804	7,214	-	-
Cottonwood Expansion - Library	1,923,562	-	1,923,562	-	-
Cottonwood Expansion - Well/Tank/Relos	2,242,876	100,000	2,342,876	-	-
Currie Ranch New School	604,331	-	604,331	-	-
Hamilton K8 2 Story Expansion - Classrooms	332,570	-	332,570	-	-
Hemet Elementary Campus Safety	373,983	-	262,356	111,627	-
Hemet High - Modernization Phase 1 & 1A	18,469,865	217,688	18,687,553	-	-
Hemet High - Expansion Phase 2 Theater & Classrooms	4,574,439	2,110,677	6,000,084	656,450	28,583
Hemet High - Expansion Phase 2 QSCB BAN	18,668,836	-	17,675,039	4,630	989,166
Hemet High - Modernization Phase 3-4	79,660	-	76,402	1,800	1,458
Hemet High - Modernization Phase 3-4 QSCB BAN	15,990	-	13,058	-	2,933

Site	Budget	Interest & Misc. Rev.	Spent	Encumbered	Uncommitted
Hemet High - Misc. Projects Security/Modernization	555,195	-	501,621	51,308	2,266
Hemet High - Expansion Stadium & Classrooms	1,388,634	-	1,388,634	-	-
Hemet High - Expansion Weight Room/Retention Basin	2,086,106	-	2,086,106	-	-
Idyllwild – Modernization Mechanical Systems & Safety	738,896	-	515,799	177,295	45,802
Little Lake Safety	90,056	6,537	96,593	-	-
Page Ranch New School	865,879	-	865,879	-	-
Ramona Site Improvements Shade Structure	747	-	747	-	-
Ramona Facilities Equipment	1,199	551	1,750	-	-
Rancho Viejo Middle New School	19,592,032	-	19,592,032	-	-
Santa Fe Campus Site Improvements	38,773	-	38,773	-	-
Santa Fe Campus Life Skills Relocation	55,427	136,624	192,052	-	-
Santa Fe Campus Helen Hunt Relocation	10,650	-	10,650	-	-
Tahquitz High School New School / Safety	29,438,900	-	29,438,900	-	-
Valle Vista Campus Security, Safety & Technology	48,578	-	48,578	-	-
West Valley High Site Improvements & Equipment	2,627,175	100,000	2,727,175	-	-
Whittier Site Improvement & Equipment	30,284	106,750	122,234	14,800	-
Winchester Site Improvement & Equipment	49,262	-	49,262	-	-
UNALLOCATED - QSCB	4,658,393	4,619,761	-	-	9,278,154
UNALLOCATED - Measure T	4,296,036	13,376,369	-	-	17,672,404
Issuance Costs - Measure T Bond	686,700	-	686,700	-	-
Issuance Costs - QSCB BAN	1,656,781	-	1,656,781	-	-

Site	Budget	Interest & Misc. Rev.	Spent	Encumbered	Uncommitted
Measure T Only	101,097,570	7,404,392	92,483,120	6,014,867	10,003,976
QSCB BAN Only	25,000,000	13,376,369	19,344,878	4,630	19,026,860
Bond Total	126,097,570	20,780,761	111,827,998	6,019,497	29,030,836

Calculations rounded to the nearest dollar

12. CONCLUDING STATEMENT

As of December 31st, 2012, \$10,003,975.78 of the Measure T funds remain uncommitted and are planned to be allocated to the Acacia Middle School Modernization Project.

Two of the three new schools approved under Measure T are completed; Rancho Viejo Middle School and Tahquitz High School. The third school, Page Ranch Elementary was placed on hold due to the sudden decline of the economy, development of new homes, and decline in overall district enrollment. The District does not expect to complete this project under Measure T at this time.

The District has completed upgrades and major repair work on twelve of the fourteen schools approved under Measure T. The largest project in this category is the renovation of Hemet High School which totaled over \$47 million. Section 11.1 of this report provides the details of the amounts spent on each project.

Hemet High School was divided into six phases or subprojects. Phases 1, 1A, and 2 are completed as well as the Stadium expansion, Weight Room and Retention Basin. The current Phase 3 work will be completed in June 2013, and the new classroom buildings were ready for the 2012-13 school year.

Acacia Middle School Phase 1 renovation and upgrade will fix the onsite drainage and flooding problems, and build a new gymnasium. Work is anticipated to begin at Acacia Middle School early 2013.

Projects remaining, such as Hemet Elementary School and Whittier Elementary repairs, will depend on future state and local funding.

The Committee continues to be impressed with the District staff's diligence and attention to detail that has resulted in the completion of Hemet High School ahead of schedule and within budget. Thanks to the efforts of the District staff and Hemet High School's outstanding administration and staff, Hemet High School has already established itself as a first-class high school and a campus worthy of the public trust placed in the Hemet Unified School District by virtue of the passage of Measure T.

Respectfully submitted,

Kathy Bloom-Rudibaugh

Dale Brusewitz

On behalf of the

Independent Citizens' Oversight Committee
Hemet Unified School District
Measure T

**HEMET HIGH SCHOOL MODERNIZATION
PHASE II**



New 2-Story Classroom Building



New classroom furniture



Security Cameras Installed



LCD Projectors Installed



New 2-Story Science Building



Science Lab



New courtyard with three new shade shelters



Entrance to New Theater



500 Seat Capacity and Sound Booth





Theater Lobby with display cases and ticket booth



Dressing rooms



Lobby Restrooms



Wheelchair Lift

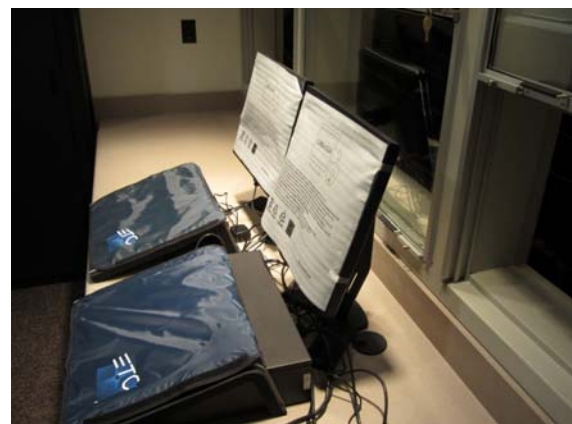

Sound booth

OLD THEATER REMODEL - 2012



New level concrete floor in old theater



Drywall installed for remodeled classroom

OLD SCIENCE BUILDING REMODEL - 2012



Lab equipment removed



New paint, carpet, and furniture

ACACIA MIDDLE SCHOOL MODERNIZATION

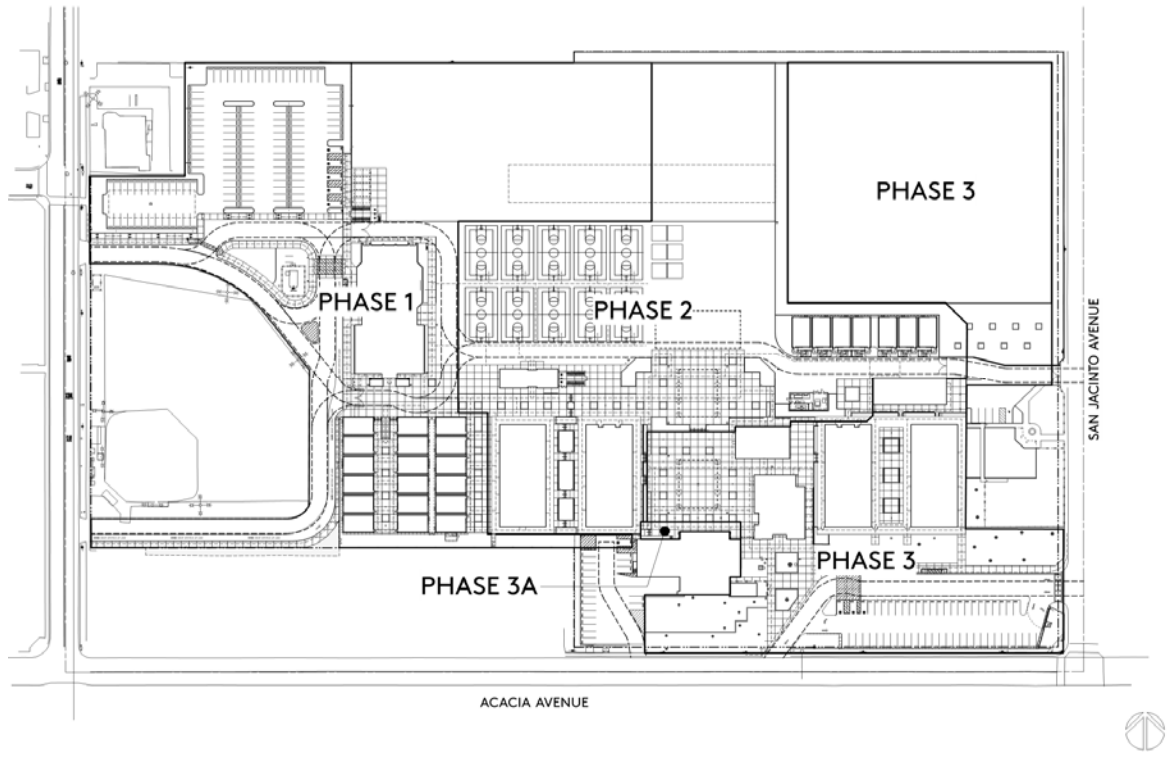

Project consists of four phases spanning January 2013 through August 2015

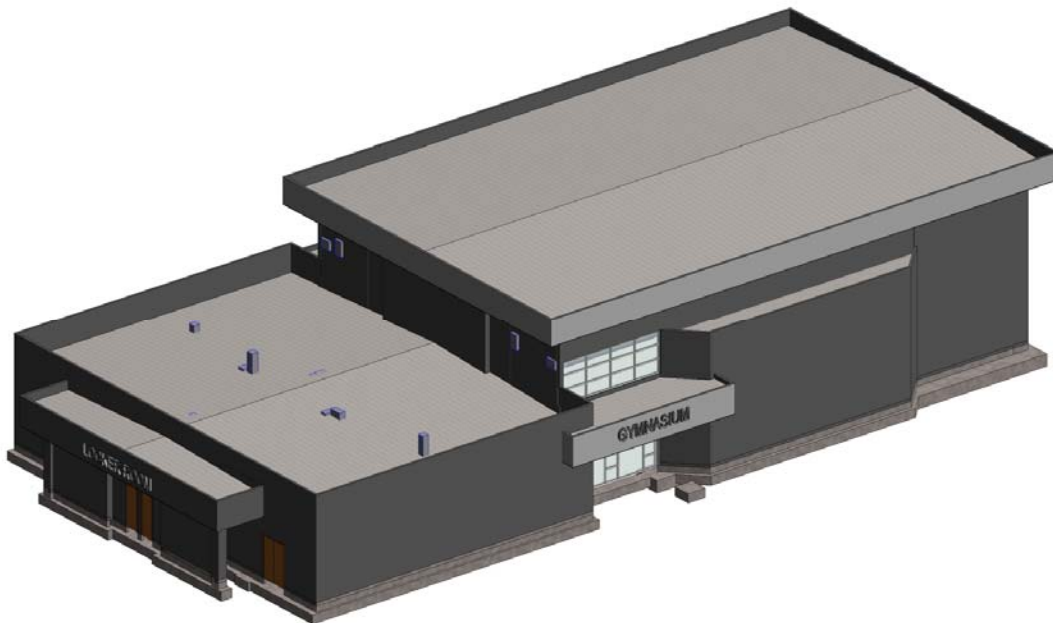

New Gymnasium projected opening December 2013

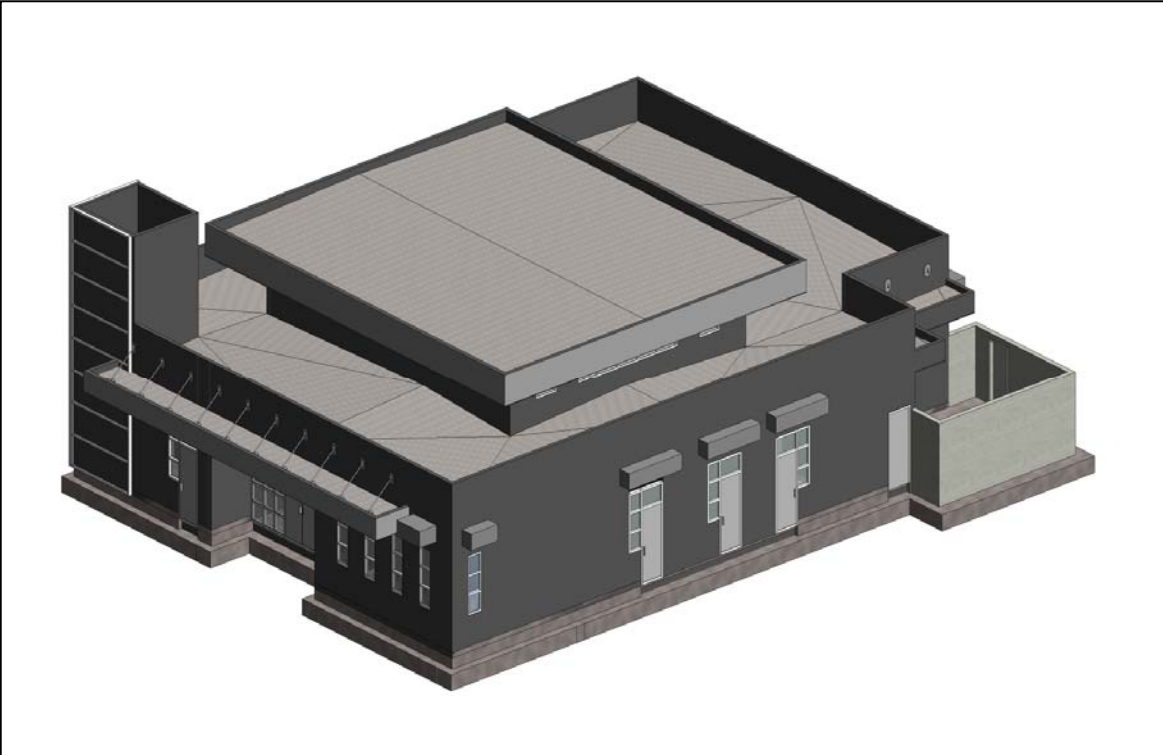

New Administration Building



Completed Project Rendering